



**Malarkey**  
**Roofing Products®**

# **SPEC MANUAL**

B.U.R., MODIFIED & SHINGLE  
ROOFING SYSTEMS

## **Chapter 4C**

Paragon® CHROMA Cap  
Installation Instructions

**GENERAL INSTRUCTIONS**

Malarkey Roofing Products® 350 Paragon® CHROMA Cap mineral-surfaced roll roofing product (CHROMA Cap) is ideal for low-slope roofs over porches and outbuildings like detached garages, sheds, and other residential utility structures. CHROMA Cap should not be applied on roofs having a slope less than 1" (25 mm) per 12" (305 mm). The slope or incline must be such that water runs off freely and does not pond on the surface.

CHROMA Cap is installed granule side up and parallel to either the eave or rake, starting at the lowest point of the roof deck and working up toward the hip or ridge.

For current warranty information, visit [www.malarkeyroofing.com/warranty-center](http://www.malarkeyroofing.com/warranty-center).

**Storage and Handling**

- Store rolls of CHROMA Cap *on end* and off the floor on pallets.
- Condition the rolls for 24 hours at a minimum of 50°F (10°C) prior to installation.
- Unroll the material, and cut into manageable 12'-18' (3.7 m - 5.5 m) lengths.
- In cooler weather, allow the sheets to relax prior to installation.

**Materials**

- Fasteners: Use common, 12-gauge roofing nails, corrosion-resistant, with heads at least 3/8" (10 mm) in diameter. Nails should be long enough to penetrate through all layers of roofing materials and at least 3/4" (19 mm) into the roof sheathing. Where the roof sheathing is less than 3/4" (19 mm) thick, the fasteners shall penetrate *through* the sheathing.

Nails must be driven flush to the membrane surface and not overdriven, underdriven, or driven at an angle.

*The use of staples is not an approved fastening method.*

- Roofing adhesive/cement: Trowel grade adhesive compliant with ASTM D3019 or ASTM D4586.
- Optional Underlayment: Malarkey Right Start™ UDL (SBS polymer modified fiberglass underlayment).

**Preparation of the Roof Deck**

- Sweep the deck entirely free of debris. The surface should be dry, clean, and smooth.

**Install Drip Edge Flashing**

- Install metal *drip edge flashing* (drip edge) along the perimeter edges of the roof. Flashing provides efficient water-shedding at the rakes and eaves and protects the underlying wood deck from rotting.

- It should be made of corrosion-resistant material and have dimensions large enough to both position the top flange of the metal 2" (51 mm) back from the edge of the roof deck and extend outward, down over the edge.
- Apply drip edge to the eaves first and then the rakes. Secure the flashing to the roof deck with nails centered on the top flange of the metal at 8" (203 mm) to 10" (254 mm) on center.

**Lap Sealing Instructions**

- Before laying an upper course over a lower, apply roofing adhesive evenly in a continuous layer approximately 1/8" thick (3 mm) over the full width of the anticipated lap. Cautionary note: Too much of this *lap adhesive* can cause blistering.
- Then press the lower end of the upper course down onto the adhesive until a small bead appears along the edge of the sheet.

**ROOFING APPLICATION PARALLEL TO THE EAVES**

**Concealed Fastener Installation (Slopes of 1" [25 mm] Per Foot or Greater)**

For maximum service life, *concealed fastener installation* is the preferred method of application. As the name implies, concealing fasteners beneath the roofing material limits the number of possible entry points for moisture intrusion.

The drawing below illustrates general installation procedures, including roofing material placement, lapping, nailing and sealing/cementing. (See Figure 1)

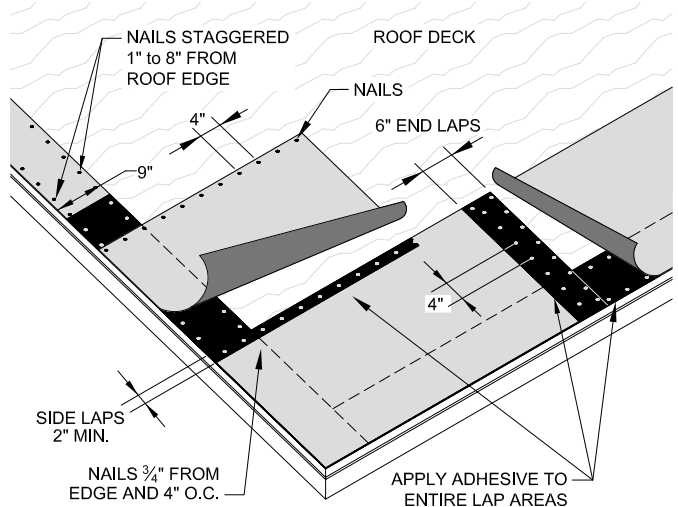

**Figure 1 - Application of CHROMA Cap: Concealed Fastener Installation**

**Edge Strips**

Edge strips (and adhesive to follow) seal perimeter edges of the roof and help prevent wind from getting under the roofing.

- Cut 9"-wide (229 mm) strips of CHROMA Cap, and place them along the entire length of the eaves and rakes, butting them loosely together, and positioning to overhang the deck and drip edges by ¼" - ¾" (6-19 mm).
- Fasten the strips with rows of nails located 1" (25 mm) and 8" (203 mm) from the roof edge and spaced 4" (102 mm) on center in each row.

## First Course

- Position a full-width strip of roll roofing at a lower corner of roof and flush with the edge strips at the eave and rake.
- Fasten the upper edge with nails placed roughly ¾" (19 mm) from the edge and spaced 4" (102 mm) on center. Do not apply nails within 18" (457 mm) of the rake until adhesive has been applied to the edge strip and the overlying course pressed down. Locate the nails so the subsequent course completely overlaps and conceals them.
- Carefully lift the lower edge of the first course, and completely cover the rake and eave edge strips with adhesive.
- Press the lower edge and rake ends of the first course firmly down onto the adhesive-covered edge strips.
- Using a membrane roller, work from one side of the sheet to the other to flatten the material, obtain full adhesion, and avoid wrinkling or bubbling.
- With the roofing in place, finish nailing the upper edge out to the rake.
- Should your material not be long enough to complete a full row, lap the ends 6" (152 mm) and nail the underlying sheet in rows 1" (25 mm) and 5" (127 mm) from the end of the sheet with the nails spaced 4" (102 mm) on center and slightly staggered.
- Apply adhesive over the full end lap area, and press the overlying end firmly down on the lower.
- End laps in succeeding courses should be offset at least 18" (457 mm).

## Second Course and Those to Follow

- Position the second course so it overlaps the first course by at least 2" (51 mm).
- Starting 18" (457 mm) in from the rake, fasten the upper edge to the deck, cement the laps and edge strips, and finish installing the sheet in the same manner as the first course.
- Follow the same procedure for each successive course.

## Hips and Ridges

- Trim and butt the CHROMA Cap completely up to,

but not over, the joint formed by a hip or ridge in the roof line.

- Fasten in place.
- Cut 12"-wide (305 mm) strips across the width of the cap sheet and prepare them for application by bending them lengthwise over the hip or ridge so 6" (152 mm) of the material lays on each side of the joint. Adequately warming the strips prior to application will prevent them from cracking.
- Start hips at the eave and ridges at the end opposite the direction of prevailing winds.
- Apply adhesive evenly to the underside of the first folded strip, fit it over the joint, and press down firmly. Use a membrane roller to ensure proper adhesion.
- On each side of the hip or ridge, drive a nail 5½" (140 mm) from the edge of the end that will be lapped by the next strip.
- Each succeeding strip should overlap the lower by 6" (152 mm). Apply adhesive, position, roll, and fasten them in the same manner as the first.
- Continue until the end of the hip or ridge is reached.

(See Figure 2)

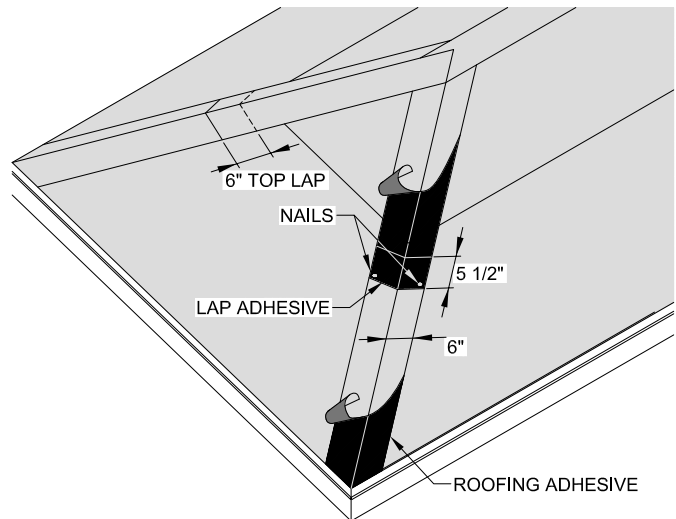
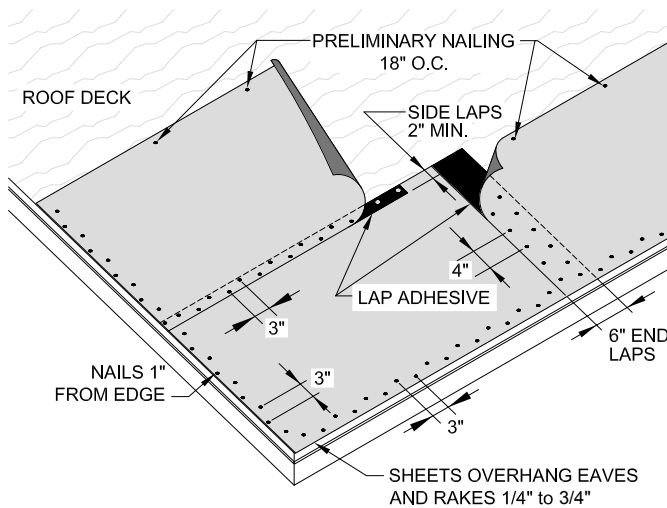

**Figure 2 - Hips and Ridges: Concealed Fastener Installation**

## EXPOSED FASTENER INSTALLATION (SLOPES OF 2" [51 MM] PER FOOT OR GREATER)

Assume roof valleys were prepared and drip edge flashing applied as per application of concealed fastener installation/roll roofing parallel to the eaves. This installation does not include edge strips.

The drawing below illustrates general installation procedures, including roofing material placement, lapping, nailing and sealing/cementing. (See Figure 3)



**Figure 3 - Application of CHROMA Cap: Exposed Fastener Installation**

**First Course**

- a. Position a full-width sheet at a lower corner of roof so its lower edge and end overhangs the eave and rake by 1/4" - 3/4" (6-19 mm).
- b. Apply initial fasteners along a line roughly 3/4" (19 mm) from the top edge of the sheet, spacing them 18" (457 mm) to 20" (508 mm) apart. This preliminary nailing is intended to hold the sheet in place until a second course is placed over it and fastened.
- c. Nail the eave and rakes on a line 1" (25 mm) from, and parallel to, the edges of the roofing with the nails spaced 3" (76 mm) on center and staggered along the eave.
- d. If two or more sheets must be used to continue the course, lap them 6" (152 mm).
- e. Apply adhesive to the underlying edge over the full width of the vertical end lap.
- f. Press the overlapping sheet down into it and use a membrane roller to ensure proper adhesion.
- g. Secure the end lap with two rows of nails 4" (102 mm) apart and 4" (102 mm) on center.
- h. For subsequent courses, offset end laps so an end lap in one course is never positioned over the end lap in another.

**Second Course and Those to Follow**

- a. Position the second course so it overlaps the first by at least 2" (51 mm). For increased weatherability, increase side laps to 3"- 4" (76-102 mm), and snap chalk lines to keep courses straight.
- b. Fasten the second course applying initial fasteners along a line roughly 3/4" (19 mm) from the top edge of the sheet, spacing them 18" (457 mm) to 20" (508 mm) apart.

- c. Lift the lower edge of the overlapping second course, and apply adhesive evenly over the upper 2" (51 mm) of the first course; then press the overlapping sheet down onto it. Roll to ensure adhesion.
- d. Fasten the lap with nails spaced 3" (76 mm) on center and staggered slightly. Place the nails not less than 3/4" (19 mm) from the edge of the sheet.
- e. Fasten the rake edges in the same manner as the first course.
- f. End laps should be 6" (152 mm) wide, cemented and nailed in the same manner as the first course.
- g. Follow Steps 1 and 2 for each successive course until you reach the top.

**Hips and Ridges**

- a. Trim and butt the CHROMA Cap completely up to, but not over, the joint formed by a hip or ridge in the roof line.
- b. Fasten in place.
- c. Cut 12"-wide (305 mm) strips across the width of the cap sheet and prepare them for application by bending them lengthwise over the hip or ridge so 6" (152 mm) of the material lays on each side of the joint. Adequately warming the strips prior to application will prevent them from cracking.
- d. Start hips at the eave and ridges at the end opposite the direction of prevailing winds.
- e. Apply adhesive evenly to the underside of the first folded strip, fit it over the joint, and press down firmly. Roll to ensure adhesion.
- f. Fasten the strip to the deck with two rows of nails, one on each side of the hip or ridge. Apply fasteners 3/4" (19 mm) from the edges of the strip and space them 3" (76 mm) on center.
- g. Be sure nails penetrate the cemented area underneath as this will seal the nail holes with asphalt.
- h. Each succeeding strip should overlap the preceding by 6" (152 mm). Apply adhesive, position, roll, and nail them in the same manner as the first.
- i. Continue until the end of the hip or ridge is reached. (See Figure 4)

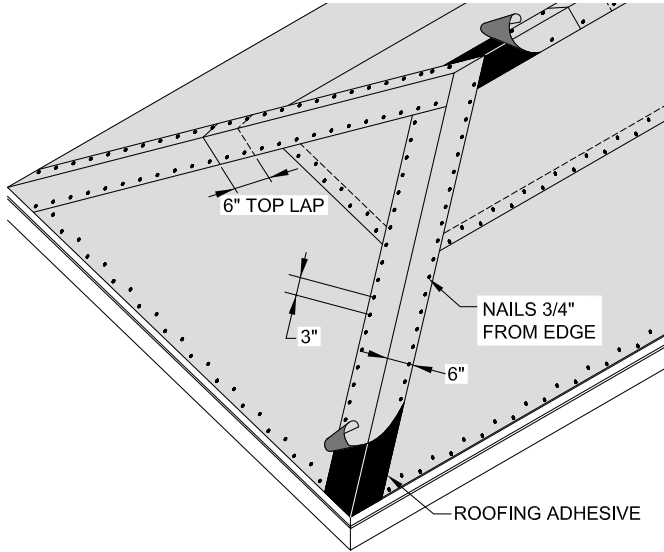
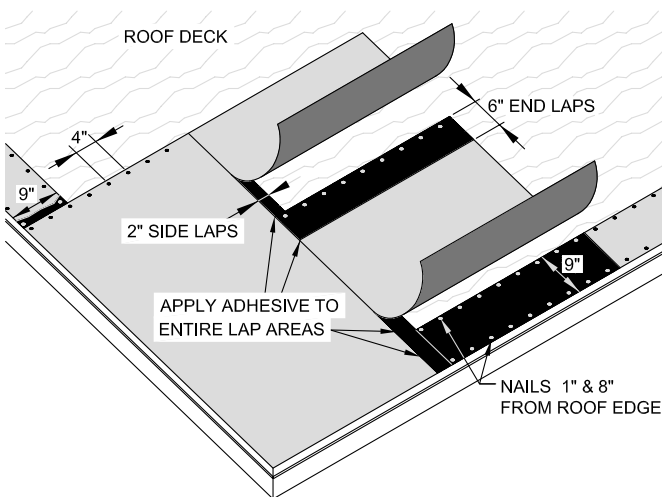

**Figure 4 - Hips and Ridges: Exposed Fastener Installation**

## ROOFING APPLICATION PARALLEL TO THE RAKES

Assume roof valleys were prepared, and drip edge flashing and edge strips applied as per application of roll roofing parallel to the eaves.

The drawing below illustrates general installation procedures, including roofing material placement, lapping, nailing and sealing/cementing. (See Figure 5)



**Figure 5 - Application of CHROMA Cap Parallel to the Rakes**

### First Course

- Position a full-width strip of CHROMA Cap so its lower edge and side are flush with the edge strips at the eave and rake.
- Fasten the upper end with nails placed roughly  $\frac{3}{4}$ " (19 mm) from the edge and spaced 4" (102 mm)

on center. Do not apply nails within 18" (457 mm) of the rake until adhesive has been applied to the edge strip and the overlying course pressed down.

- Carefully lift the lower end of the first course, and pull it back, exposing the eave and rake edge strips. Apply adhesive to the edge strips according to the lap sealing instructions.
- Press the lower edge and rake sides of the first course firmly into the adhesive-covered edge strips.
- Using a membrane roller, work up and down and side to side to flatten the material, obtain full adhesion, and avoid wrinkling or bubbling.
- With this course in place, finish nailing the upper edge out to the rake.
- Continue up the roof to the hip or ridge, applying additional lengths of CHROMA Cap and overlapping lower courses by 6" (152 mm). Apply adhesive to these end laps, and roll to ensure adhesion.

### Second Course and Those to Follow

- Position the second course alongside and parallel to the first course with a side lap at least 2" (51 mm). For increased weatherability, increase side laps to 3"- 4" (76 -102 mm), and snap chalk lines to keep courses straight.
- As with the first course, fasten the upper end with nails roughly  $\frac{3}{4}$ " (19 mm) from the edge and 4" (102 mm) on center.
- Lift the lower end of the sheet, and apply adhesive to the edge strip at the eave and the entire length of the side lap with course one.
- Press the sheet down onto the adhesive, and use a roller to flatten and adhere the material.
- Continue up the roof, applying additional lengths of CHROMA Cap and overlapping lower courses by 6" (152 mm). Apply adhesive to these end laps, and roll to ensure adhesion.
- Follow the same procedure for each successive course until the roof face is covered.

### Final Course

- For the course closest to the far edge, do not apply fasteners within 18" (457 mm) of the rake until adhesive has been applied to the eave and rake edge strips.
- Once pressed down and firm, finish nailing the top edge out to the rake.

### Hips and Ridges

Finish hips and ridges in the same manner as those in the *Concealed Fastener Installation Instructions*.

## FINAL NOTE

These instructions are meant to act as a general guide. If you have questions about this installation or any Malarkey roofing product, please contact our Technical Services Department weekdays at (800) 545-1191 or (503) 283-1191, 7:00 am to 5:00 pm, Pacific Standard Time. You can also email us at [technicalinquiries@malarkeyroofing.com](mailto:technicalinquiries@malarkeyroofing.com). Thank you.