

# Sustainably Designed, High-Performance Roofing Shingles

Rubberized Asphalt Technology, Upcycled Tires & Plastics, Pollution-Reducing Granules

**UPCYCLED TIRES & PLASTICS**

Polymers from recycled rubber tire and plastics improve shingle durability while diverting the equivalent of ~5 rubber tires and ~2,000 plastic water bottles from the landfill per average-size roof.<sup>1</sup>

**NEX® POLYMER MODIFIED ASPHALT**

Asphalt core of shingle is rubberized with virgin synthetic rubber polymers (SBS) to enhance shingle strength, flexibility, and resilience. **Up to Class 4 impact resistance. Insurance discounts may apply.**

**POLYMER MODIFIED ADHESION**

**Up to 50% more adhesion bonds and twice the number of rain seals than standard shingles.** Proprietary synthetic rubber adhesion (SEBS) resists dry-out and delivers extreme protection from high winds, wind-driven rain, and delamination.

**3M™ SMOG-REDUCING GRANULES**

**TIME Top 50 Invention of 2018**  
Clean the air by reducing air pollution. **Each average-size roof has the smog-fighting potential of ~2 trees.<sup>2</sup>**

**THE ZONE® NAILING AREA**

**Up to 2x wider nailing and common bond area**, with a tapered shim, helps ensure shingle is properly fastened (nails penetrate both shingle layers), lays flat, and effectively sheds water to help prevent troughing.

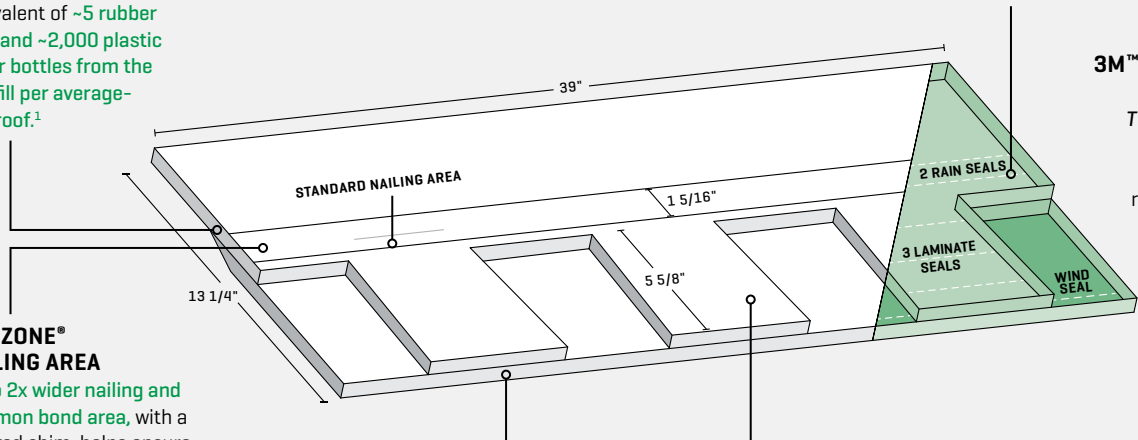

**FIBERGLASS MAT**

Provides structural reinforcement, and combined with polymer modified asphalt, **10-55% greater tear strength than the industry standard (ASTM D3462).**

**3M™ ROOFING GRANULES**

Deeply embedded, ceramic-coated granules protect shingle from weather and UV aging. **Up to 65% greater granule adhesion than the industry standard (ASTM D3462).**

**3M™ COPPER GRANULES**

Reduce black streaks caused by algae growth. **Up to Limited Lifetime algae warranty.**

Architectural & Designer Shingle Lines	GOOD HIGHLANDER® NEX®	BETTER VISTA®	BEST LEGACY® SCOTCHGARD™	Designer WINDSOR® SCOTCHGARD™
<b>Asphalt Technology</b>	NEX®	NEX®	NEX®	NEX®
<b>Impact Rating</b> (Class 4 Highest)	Class 2	Class 3	Class 4	Class 4
<b>Tear Strength*</b>	+10%	+25%	+35%	+40%
<b>Thickness</b>		+10%	+19%	+22%
<b>Cost</b>	\$	\$\$	\$\$\$	\$\$\$\$
<b>Warranties*</b>				
Limited Lifetime Shingle Warranty	Lifetime	Lifetime	Lifetime	Lifetime
Right Start™ Period [years]	10	12	15	15
'Your Choice' Warranty†	Yes	Yes	Yes	Yes
Limited Lifetime Algae Warranty**	NA	NA	Lifetime	Lifetime
Standard Wind Warranty [mph/kph/years]	110/177/10	110/177/12	110/177/15	110/177/15
Enhanced Wind Warranty [mph/kph/years]	130/209/10	130/209/12	130/209/15	140/225/15

\*VERSUS STANDARD SHINGLES, AS MEASURED PER ASTM D3462. \*\*INCLUDED ON SHINGLES WITH SCOTCHGARD™ PROTECTOR.  
 †SELECT OUR TRANSFERABLE LIMITED LIFETIME SHINGLE WARRANTY OR ONE FROM A COMPETITOR - YOUR CHOICE.  
<sup>1</sup> ASSUMES AVERAGE-SIZE ROOF OF 30 SQUARES. <sup>2</sup> SOURCE: LAWRENCE BERKELEY NATIONAL LABORATORY AND 3M.  
 IMAGE IS OF ARCHITECTURAL SHINGLE. DESIGNER SHINGLES MEASURE 19 3/4" x 38 3/4" AND DO NOT INCLUDE THE ZONE®. LEGACY SHINGLE LINE IS 40" LONG.



Distributed from South Gate, CA (color availability): [H] Highlander® NEX® [V] Vista®  
 Scotchgard™ Protector Lines include: [L] Legacy® Scotchgard™ [W] Windsor® Scotchgard™  
 CRRC rated colors can be used to comply with California Energy Code [CEC] Title 24, Part 6 Cool Roof Requirements (excludes Legacy® Scotchgard™).

## TESTIMONIALS

**Amy McLaughlin, General Manager, 3M Industrial Mineral Products**  
 "Our relationship with Malarkey dates back 50 years and has enabled 3M to bring innovative and environmentally-conscious granule technologies, such as algae resistance, solar reflectivity, and now smog reduction, to homeowners nationwide."

**Jonathan Parfrey, Executive Director, Climate Resolve**  
 "Along with planting more trees, we view smog-reducing technology, embedded into mainstream roofing materials, as a great step forward in addressing air quality."

**Jodie Morgan, CEO, GreenMantra® Technologies**  
 "Through our work with Malarkey Roofing Products, we have been able to upcycle hundreds of tons of recycling polymers, creating value from materials like plastic containers, bottle caps, and drinking straws, diverting these plastics from our landfills and oceans."

**Greg Malarkey, President, Malarkey Roofing Products**  
 "A family business, based in Oregon since 1956, we strive simply to make the best shingle in the least environmentally impactful way."

**Pat Reilly, Owner, Rain Proof Roofing**  
 "As one of the largest roofing companies in Alaska, we know extreme weather, which is why Malarkey has been at the core of our product offering for over 30 years."

**James Martinez, Homeowner**  
 "Granted, it's just one roof, but if everyone starts choosing a shingle that reduces landfill waste and also fights air pollution, who knows what the end result will be."

**Jeremy Nowak, President, Bob's Roofing**  
 "Last week, with winds up to 68 mph, we had over 100 calls for shingles blown off of roofs in our area yet didn't lose a single shingle from our Malarkey shingle line. They are made for these conditions."

**Kevin Orme, Executive Director, Indiana Department of Corrections**  
 "We started using the Legacy shingle from Malarkey in 2014 and will not use another shingle unless it can be proven to be better."



Malarkey has earned GreenCircle Certification for Waste Diversion from Landfill at all its manufacturing facilities.

**TEST COMPLIANCE:** All Shingles - ASTM D7158 Class H, ASTM D3462, ASTM D3161 Class F, ASTM D3018 Type I, ASTM E108 Class A Fire Rating, CSA A123.5, ICC Approval - ESR-3150, and FBC Approval #14809. UL 2218 Class 4 (Windsor® and Legacy® lines), UL 2218 Class 3 (Vista®), UL 2218 Class 2 (Highlander® NEX®), ICC-ES AC438 (Highlander® NEX®, Legacy®).

**DISCLAIMER:** Photographs of shingles may not accurately represent their true color or the variations of color blends that will appear on the roof. **Before installation, five or six shingles should be laid out and reviewed for desired color.** Colors and specifications subject to change without notice. Shingle colors not available in all regions or product lines. Scotchgard and Scotchgard Protector, including the 3M logo, are all trademarks of 3M.

+ For complete information on all warranties, including "Your Choice" Warranty and the Right Start™ non-prorated period against manufacturing defects, please reference **Malarkey's Shingle and Accessory Warranty available at [www.malarkeyroofing.com/warranty-center](http://www.malarkeyroofing.com/warranty-center).**

This version supersedes all previous versions. Rev. 04/21.



P.O. BOX 17217  
 PORTLAND, OREGON 97217  
 800.545.1191  
 WWW.MALARKEYROOFING.COM

MEETS CSA A123.5 STANDARDS **MADE IN USA**